

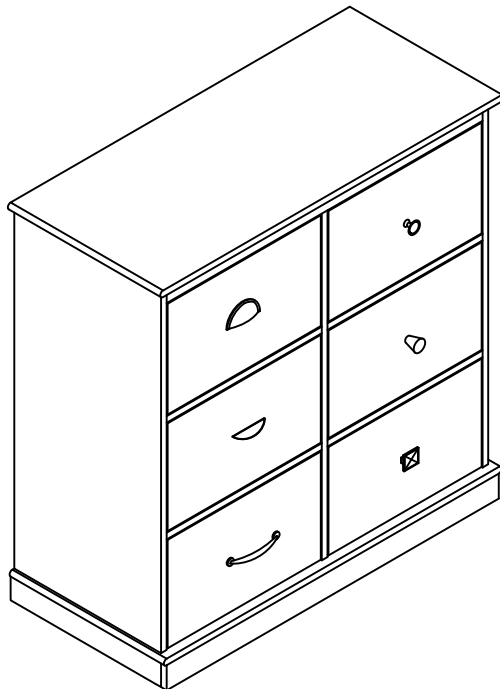

# 5072096

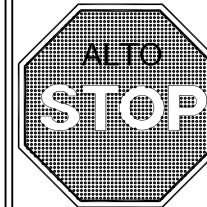

THIS INSTRUCTION BOOKLET CONTAINS IMPORTANT SAFETY INFORMATION. PLEASE READ AND KEEP FOR FUTURE REFERENCE.  
ESTE FOLLETO DE INSTRUCCION CONTIENE INFORMACION IMPORTANTE DE SEGURIDAD. POR FAVOR, LEALA Y GUARDELA PARA PODER USARLA EN UN FUTURO.



**DO NOT RETURN PRODUCT TO THE STORE**  
Individual stores do not stock parts.

**NO DEVUELVA ESTE PRODUCTO A LA TIENDA**  
Las tiendas no almacenan partes.

Lot Number / N<sup>o</sup>mero de Lote: \_\_\_\_\_

Date Of Purchase / Fecha de Compra: \_\_\_/\_\_\_/\_\_\_

If a part is missing or damaged, call our toll-free customer service line. We will gladly ship your replacement parts FREE of charge.

Si faltan partes o piezas, o éstas están dañadas, llame gratis al teléfono de servicio al cliente. Con gusto le enviaremos las partes sin cargo alguno.

Need Parts or Assistance?  
Necesitas partes o asistencia?

**1-800-489-3351**

or access our website  
to visite nuestra página de internet

[www.altrafurniture.com](http://www.altrafurniture.com)

For prompt, reliable service please have your assembly manual ready.  
Para obtener un servicio rápido y confiable, por favor guarde este manual para tenerlo siempre a mano.

Recommended # of people needed for assembly: 2  
El número recomendado de personas necesarias para el montaje: 2

B34507209600

Thank you for purchasing from Altra Furniture.  
Visit [www.altrafurniture.com](http://www.altrafurniture.com) to view the limited warranty valid in the U.S. and Canada.

## ALTRA FURNITURE CUSTOMER SERVICE

Gracias por haber comprado de Altra Furniture.  
Visitar [www.altrafurniture.com](http://www.altrafurniture.com) para mirar la garantía limitada válida solamente en U.S.A y Canada.

## SERVICIO A LA CLIENTE DE ALTRA FURNITURE

### Before starting - Antes de empezar.

- Read each step carefully before starting. It is very important that each step of instruction is performed in the correct order. If these steps are not followed in sequence, assembly difficulties will occur.  
Leer con cuidado cada paso antes de empezar. Es muy importante de ejecutar cada paso en el orden correcto. Si los pasos no están ejecutados en secuencia, ocurrirá dificultades en el montaje.
- Make sure all parts are included. Most board parts are labeled or stamped on the raw edge. Asegurar que todas las piezas son incluidas. La mayoría de las tablas tienen las etiquetas o los sellos en el lado sin acabado.
- Work in spacious area, preferably on a carpet, near the place the unit will be used. Trabajar en una área espaciosa, preferible sobre alfombra, cercas del lugar donde se va a usar el mueble.
- Have the following tools close at hand. Tener las herramientas siguientes cerca de la mano.
- Do not use power tools to assemble your furniture. Power tools may strip or damage the parts. No use herramienta eléctrica para montar su unidad. Las herramientas eléctricas pueden dañar las piezas.

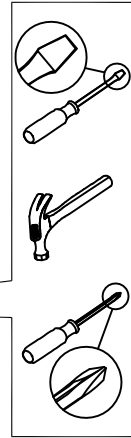

Call us at:  
Llamar a:

1-800-489-3351  
(in U.S.A. only)  
(Solo en U.S.A)

Monday - Friday 7:00 am - 8:00 pm Central Time	Saturday 9:00 am - 5:00 pm Central Time
--	---



Fax:  
Fax:

1-636-745-1005

Lunes - Viernes 7:00h - 20:00h Tiempo Central	Sabado 9:00h - 17:00h Tiempo Central
---	--



Visit our Website:

Visitar nuestro website: [www.altrafurniture.com](http://www.altrafurniture.com)



Write to:  
Escribir a:

ALTRA FURNITURE  
410 East 1st Street South Wright City, MO 63390 USA  
Attn: Service Dept.

### HELPFUL HINTS

- Visit our website for assembly video clips.
- Identify, sort and count the parts before attempting assembly.
- Call our toll free number if you need assistance identifying parts.
- Compression dowels are tapped in with a hammer.
- Slides have lips only on the right side.
- Cam locks that are properly fastened on a horizontal board will face toward the center of the unit, on a vertical board the point on the lock will face the bottom.
- Back panels provide stability and support. Use all the nails provided.
- When tapping nails into a board, be sure there are equal margins on all sides to square the unit.
- Units without the back panel installed may collapse.
- Clean the product with your favorite furniture polish and a soft cloth. DO NOT USE harsh chemicals or abrasive cleaners.
- Move your new furniture carefully, with two people lift and carry the unit to its new location.
- Never push, drag or scoot your furniture (especially on carpet).
- Your furniture can be disassembled and reassembled to move.
- Additional parts are available for a nominal fee.

### NOTES UTILES

- Visitar nuestro website para mirar los videos cortos del montaje.
- Identificar, clasificar y contar las piezas antes de intentar el montaje.
- Llamar gratis a nuestro número de servicio si necesita ayuda con identificar las piezas.
- Las clavijas de compresión se taladran con un martillo.
- Las correderas sólo tienen las proyecciones en el lado derecho.
- Las cerraduras de leva que se atan propiamente en una tabla horizontal se puntan al centro de la unidad, y las en una tabla vertical se puntan al fondo.
- Los paneles traseros se mantienen la estabilidad. Usar todos los tornillos proporcionados.
- A taladrar los tornillos en una tabla, asegurarse que hay márgenes iguales en todos los lados para cuadrar la unidad.
- Las unidades sin panel trasero pueden derrumbarse.
- Limpiar la unidad con su pulimento favorito de mueble y una tela suave. NO UTILIZAR productos con químicos duros o abrasivos.
- Mover su mueble nuevo cuidadosamente, con dos personas levantar la unidad a su nuevo lugar.
- Nunca empujar o arrastrar su mueble (especialmente en alfombra).
- Poderse desmontar y volver a montar su mueble de para mover.
- Piezas adicionales están disponibles para una cuota nominal.

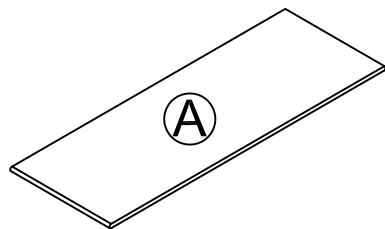

Top shelf  
Estante superior  
T5072096010

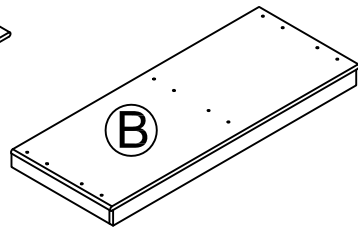

Bottom panel  
Panel del  
T5072096020

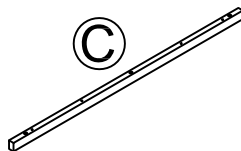

Top shelf apron  
Embellecedor para estante superior  
T5072096030

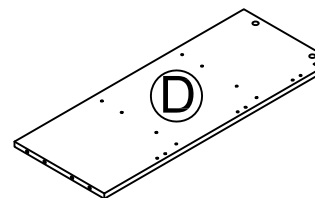

Partition panel  
Panel de partici3n  
T5072096040

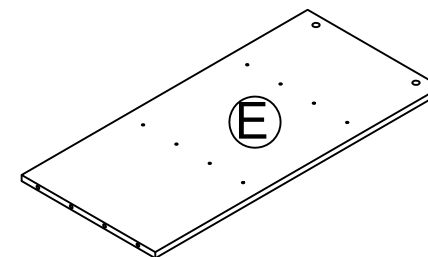

Left side panel  
Panel izquierdo  
T5072096050

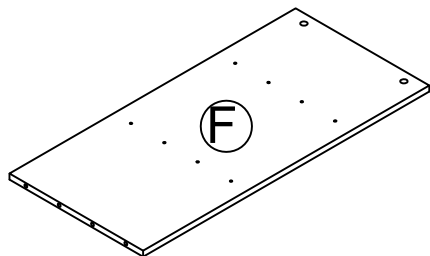

Right side panel  
Panel derecho  
T5072096060

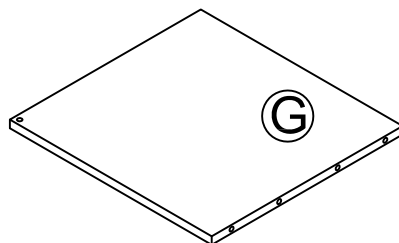

Left fixed shelf (2)  
Estante fijo izquierdo (2)  
T5072096070

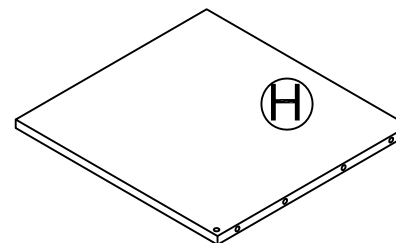

Right fixed shelf (2)  
Estante fijo derecho (2)  
T5072096080

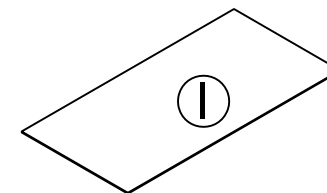

Back panel (2)  
Panel trasero (2)  
T5072096090

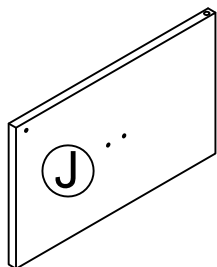

Upper left door  
Puerta izquierda superior  
T5072096100

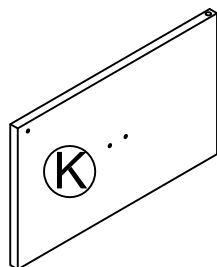

Middle left door  
Puerta izquierda en la mitad  
T5072096110

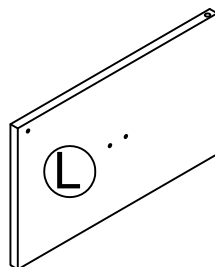

Lower left door  
Puerta izquierda inferior  
T5072096120

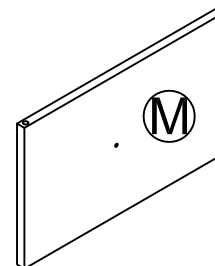

Upper right door  
Puerta derecha superior  
T5072096130

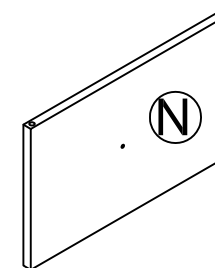

Middle right door  
Puerta derecha en la mitad  
T5072096140

PARTS -PIEZAS

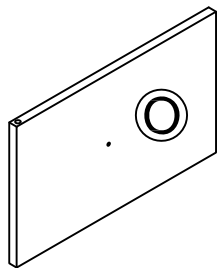

Lower right door  
Puerta derecha inferior  
T5072096150

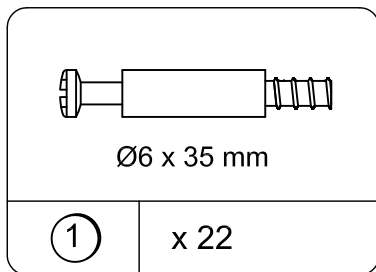

Cam bolt  
Perno de la leva  
TWQ0011

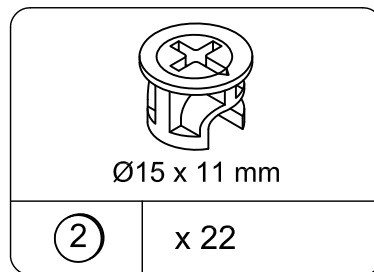

Cam lock  
Cerradura de la leva  
TWQ0012

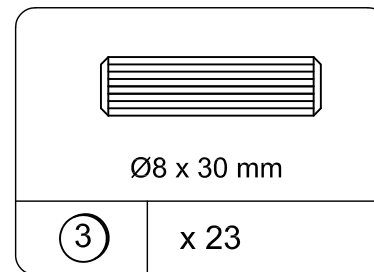

Wooden dowel  
Clavija de madera  
TWQ0003

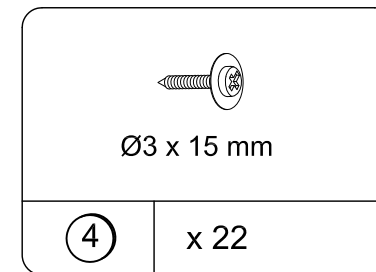

Screw  
Tornillo  
TWQ0009

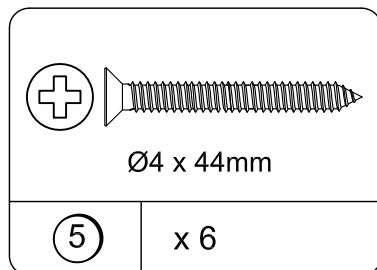

Screw  
Tornillo  
TWQ0027

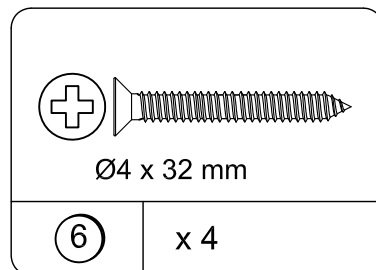

Screw  
Tornillo  
TWQ0010

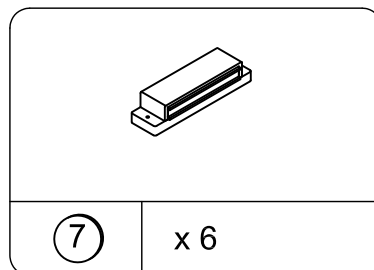

Magic catch  
Pestillo mágico  
TWQ0035

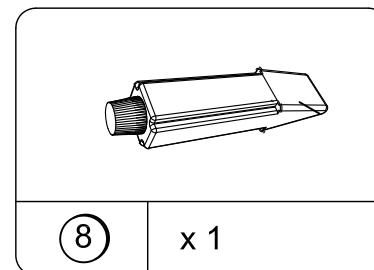

Glue  
Pegamento  
TWQ0008

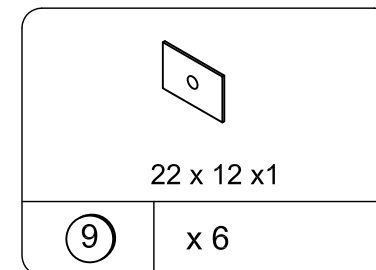

Magic catch plate  
Placa de pestillo mágico  
TWQ0036

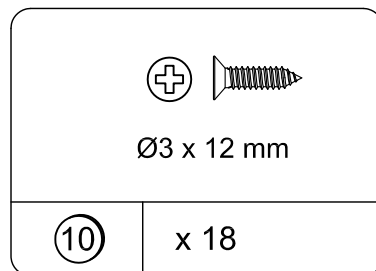

Screw  
Tornillo  
TWQ0037

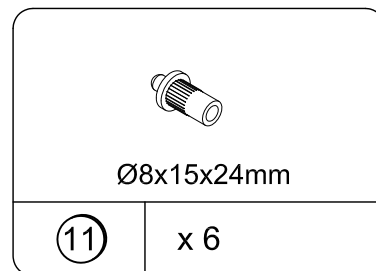

Door shaft  
Eje de puerta  
TWQ0038

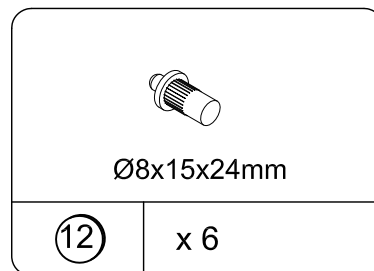

Door shaft  
Eje de puerta  
TWQ0039

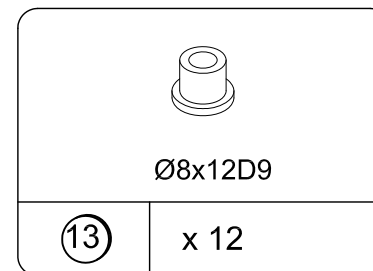

Door shaft support  
Soporte para eje de puerta  
TWQ0040

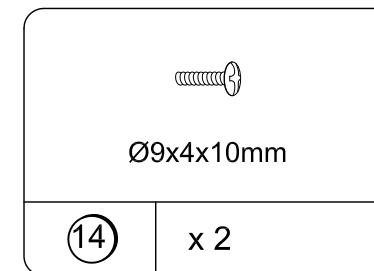

Screw bolt  
Tornillo con tuerca  
TWQ0034

# PARTS -PIEZAS

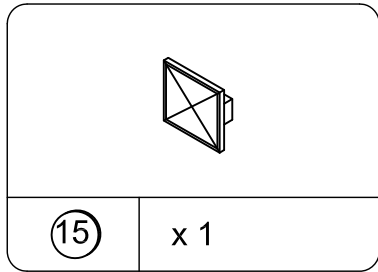

Knob  
Puno  
TWQ0029

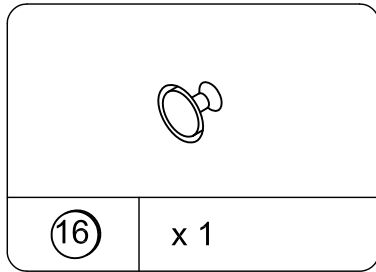

Knob  
Puno  
TWQ0030

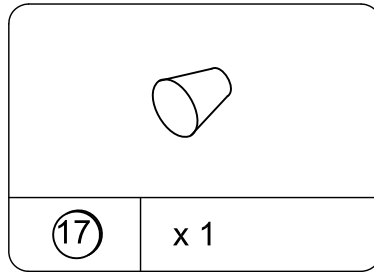

Knob  
Puno  
TWQ0041

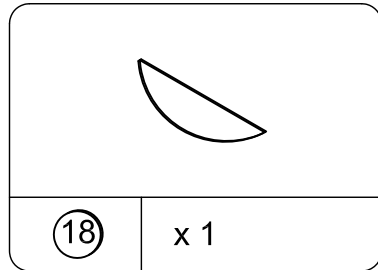

Pull  
Jalón  
TWQ0031

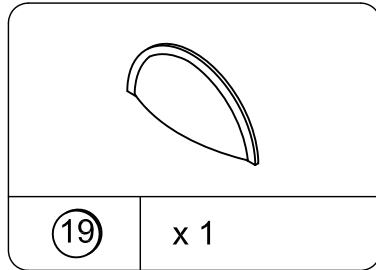

Pull  
Jalón  
TWQ0032

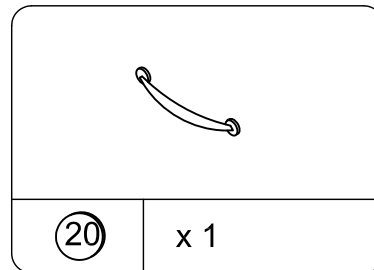

Handle  
Manija  
TWQ0042

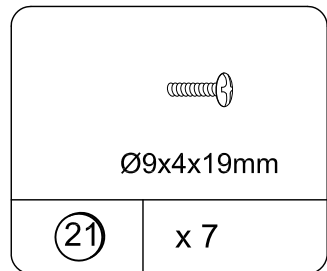

Screw bolt  
Tornillo con tuerca  
TWQ0033

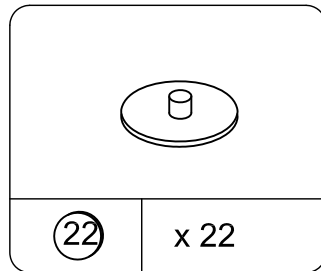

Cam cover  
Leva de cubierta  
TWQ0013

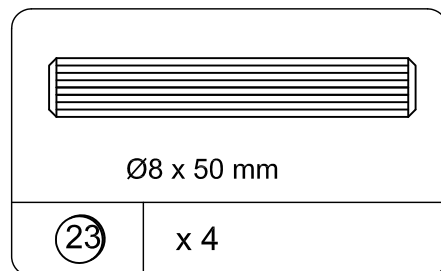

Wooden dowel  
Clavija de madera  
TWQ0055

This illustration shows how the cam fastening system works.  
Esta ilustración muestra como funciona el sistema de fijación de leva.

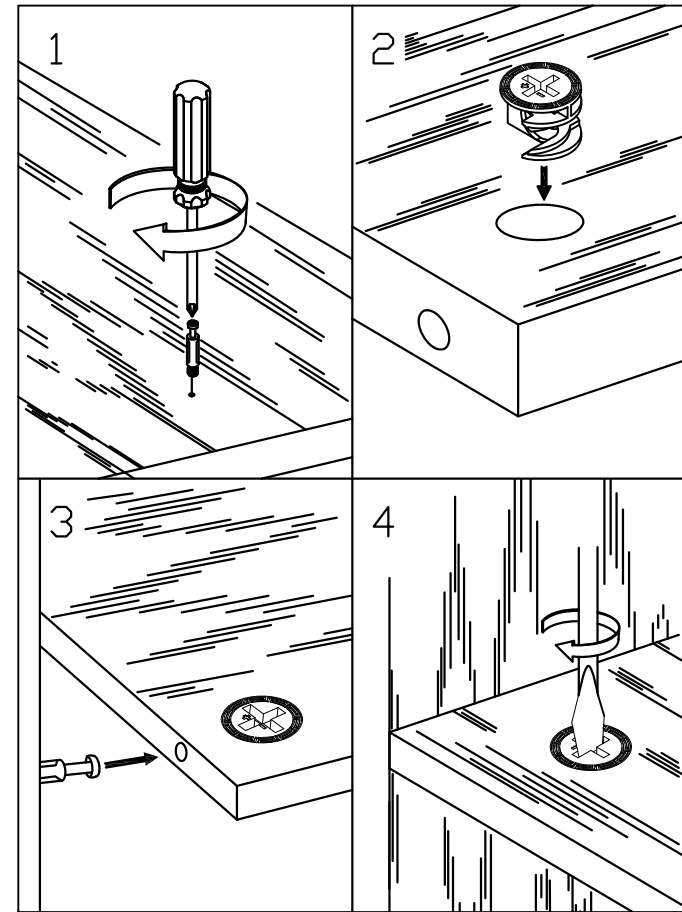

To view a video on how the cam fastening system works, download a free QR-reader on your smartphone, then scan the code.



Para ver un video de como funciona el sistema de sujeción cam, descargue una aplicación gratis que podra ver en su teléfono movil, entonces escnee el código.

# 1

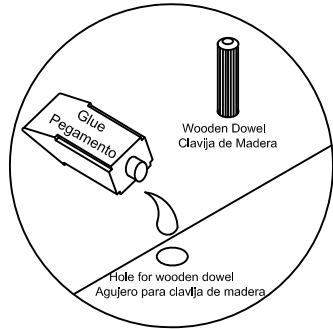

Use one drop of glue in dowel hole.  
Use una gota de pegamento en el agujero de clavija.

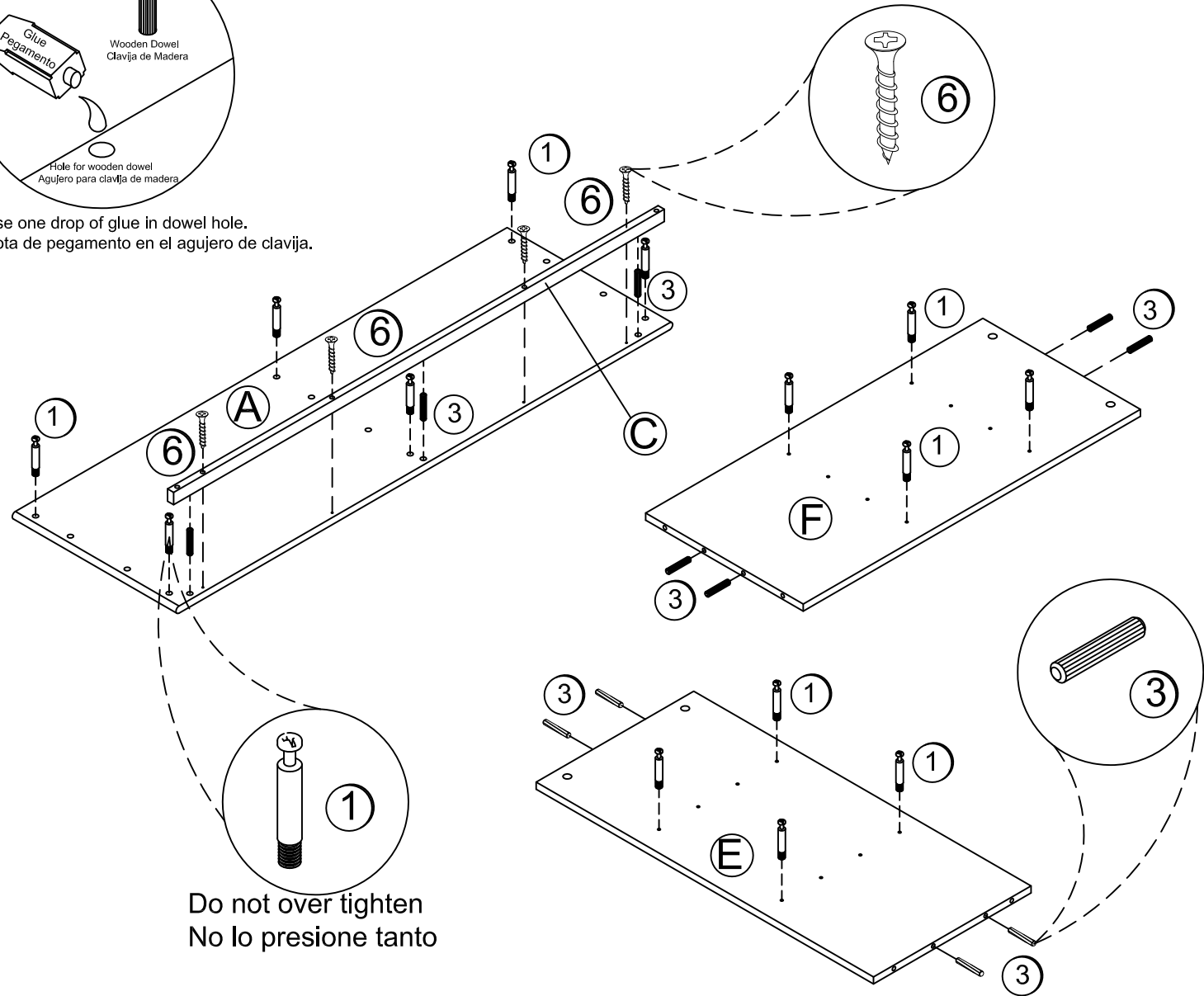
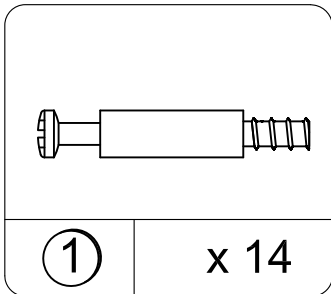
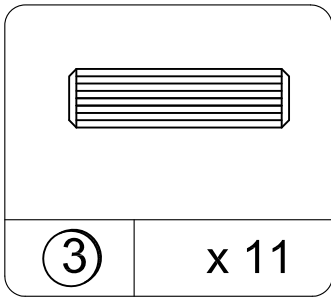
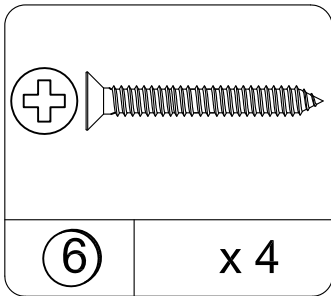

Do not over tighten  
No lo presione tanto

# 2

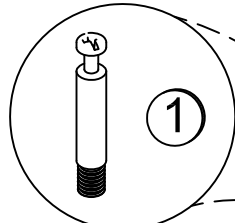

Do not over tighten  
No lo presione tanto

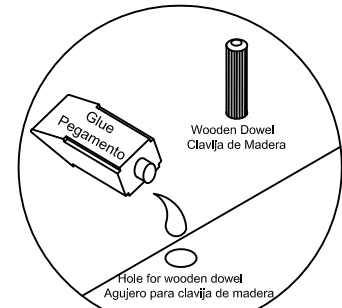
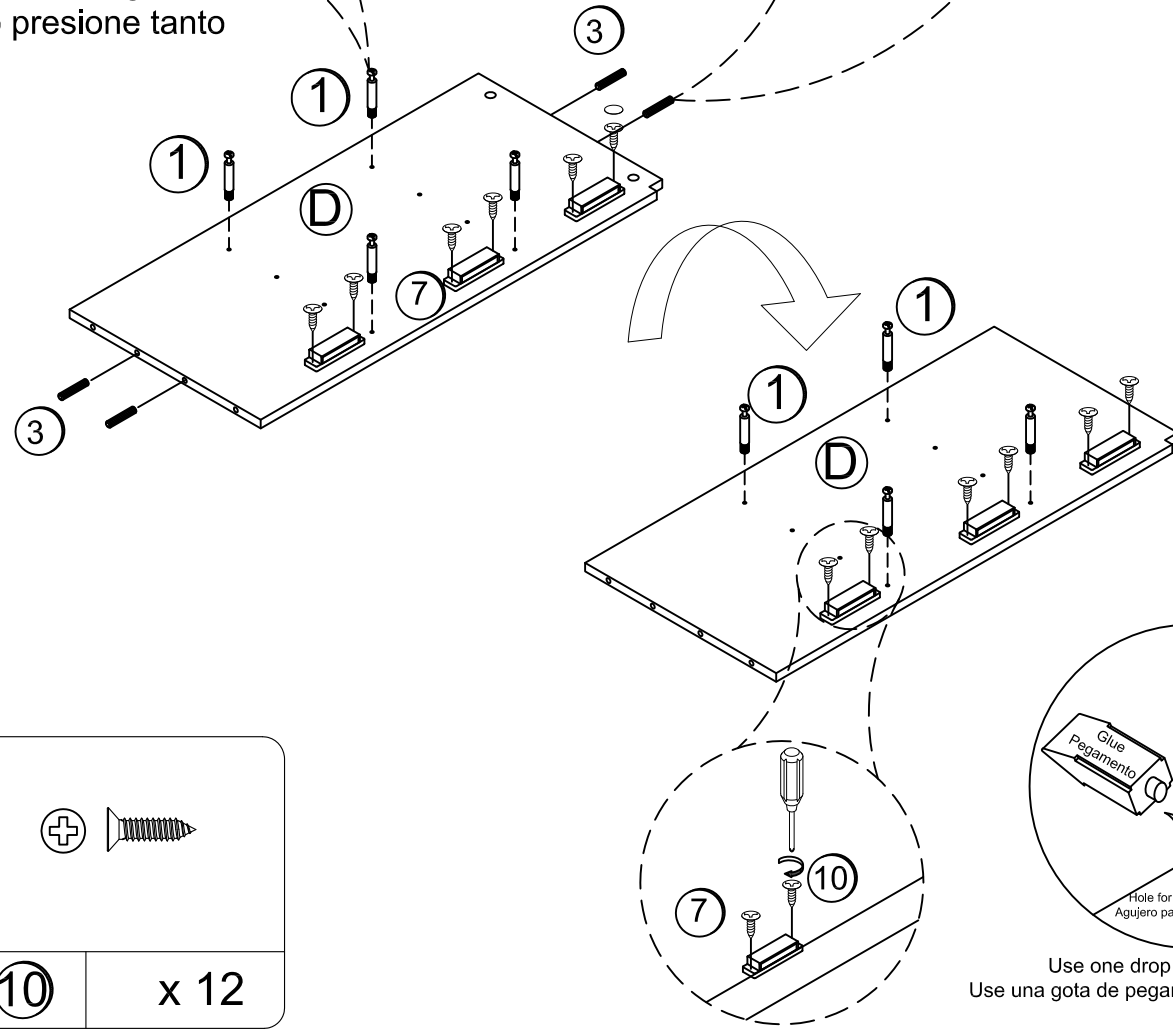
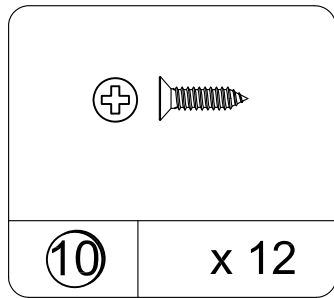
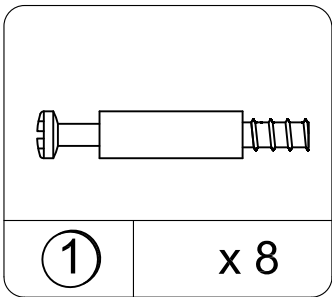
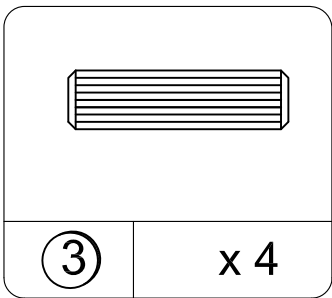
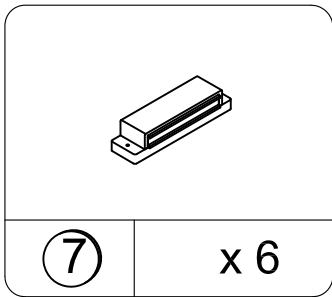
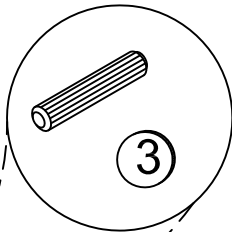

Use one drop of glue in dowel hole.  
Use una gota de pegamento en el agujero de clavija.

# 3

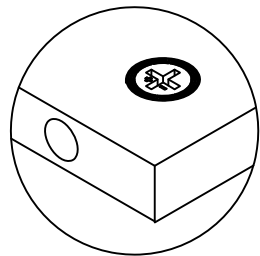
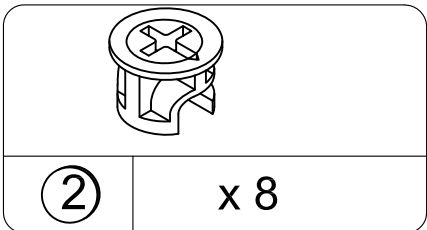
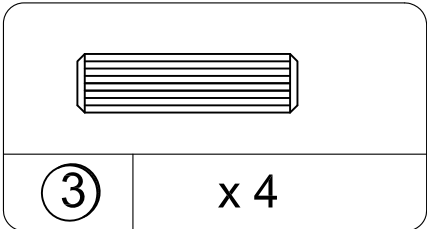
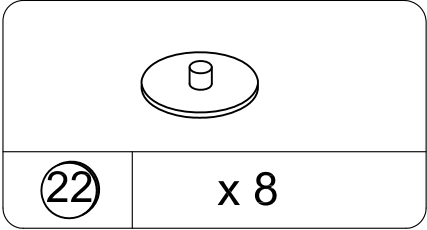
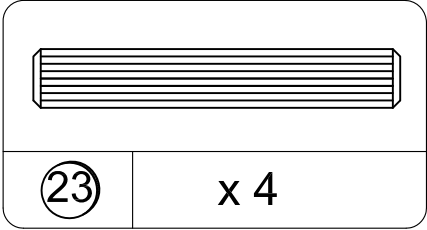
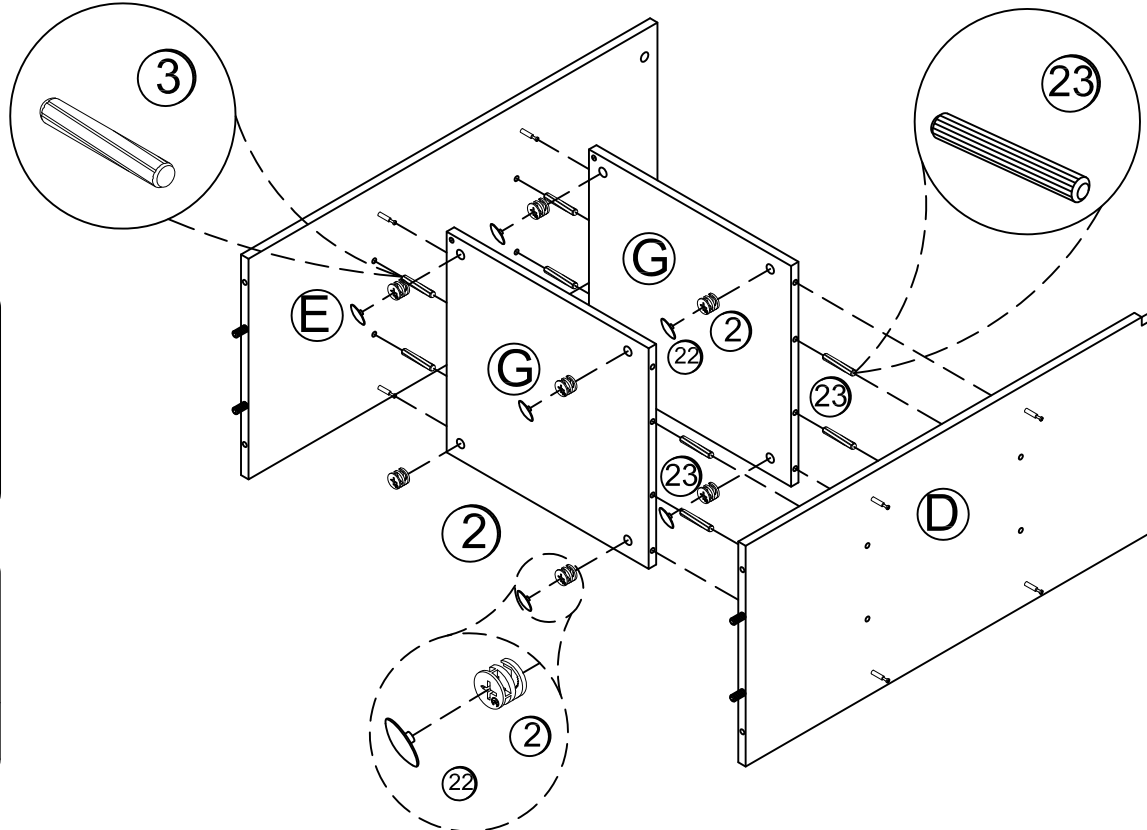

Proper orientation of cam lock  
La orientación apropiada para el seguro de bloqueo

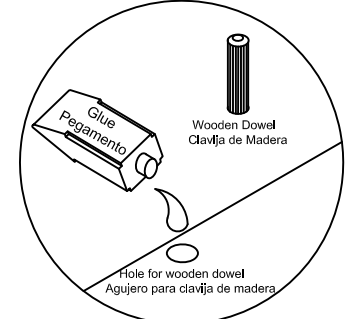
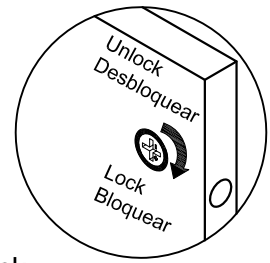

Use one drop of glue in dowel hole.  
Use una gota de pegamento en el agujero de clavija.



# 4

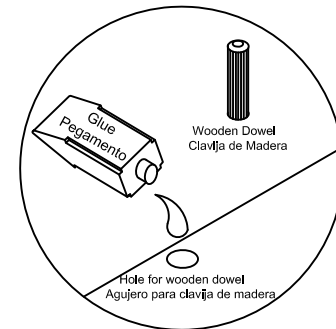
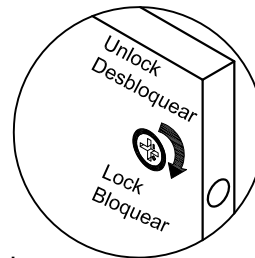
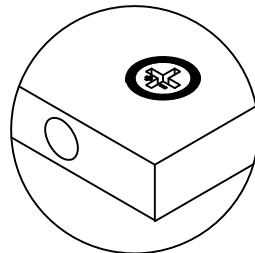
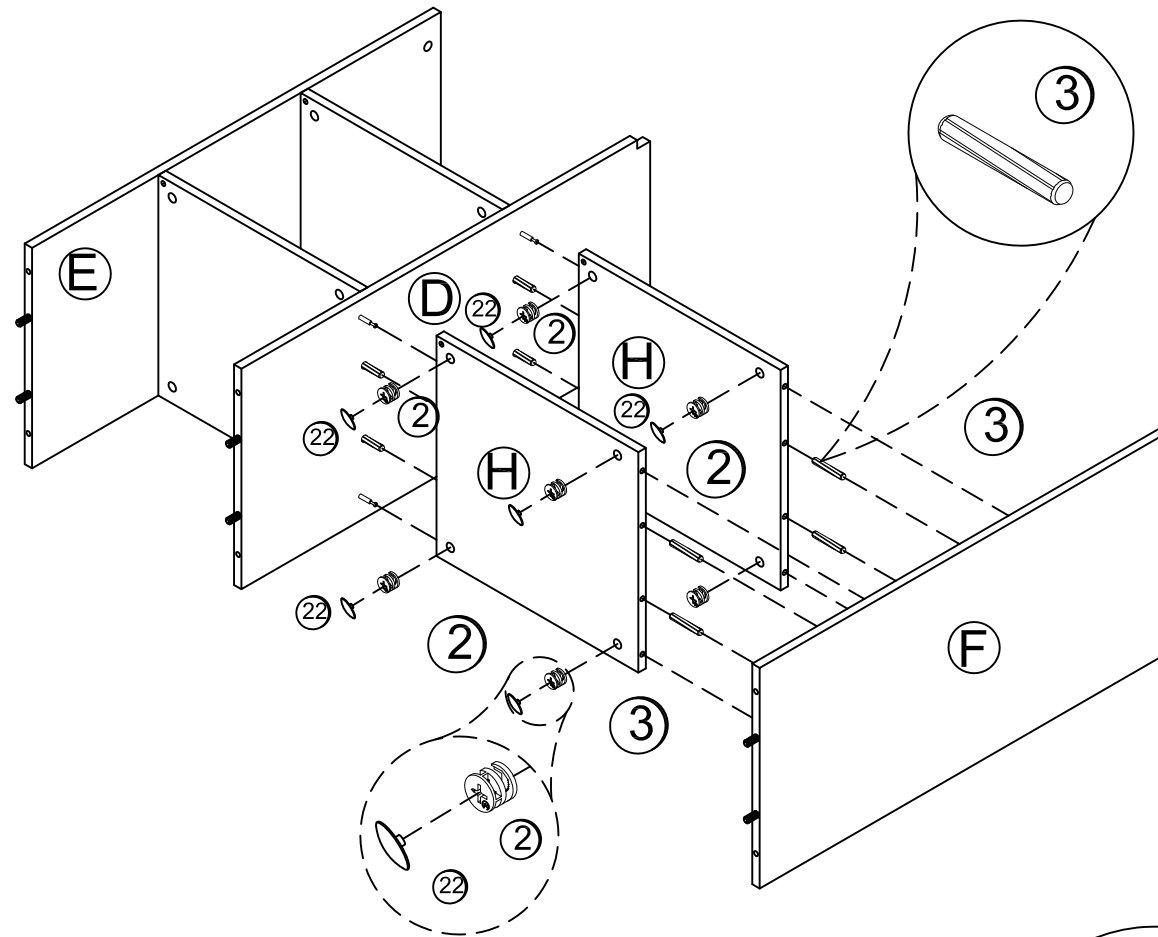
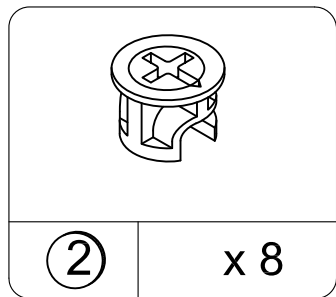
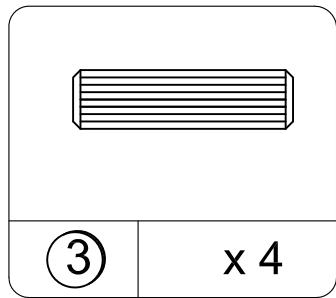
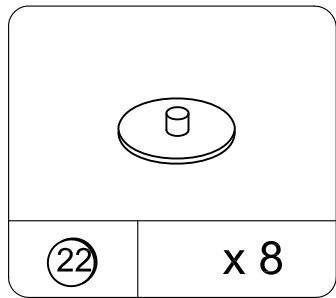

Proper orientation of cam lock  
La orientacion apropiada para el seguro de bloqueo

Use one drop of glue in dowel hole.  
Use una gota de pegamento en el agujero de clavija.

# 5

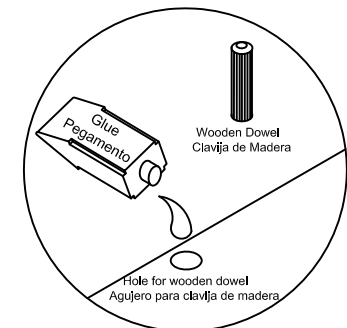
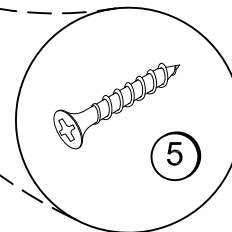
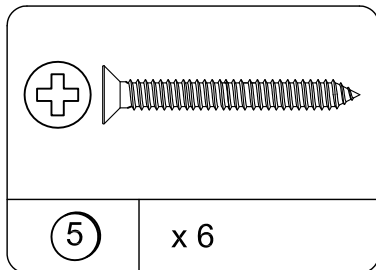
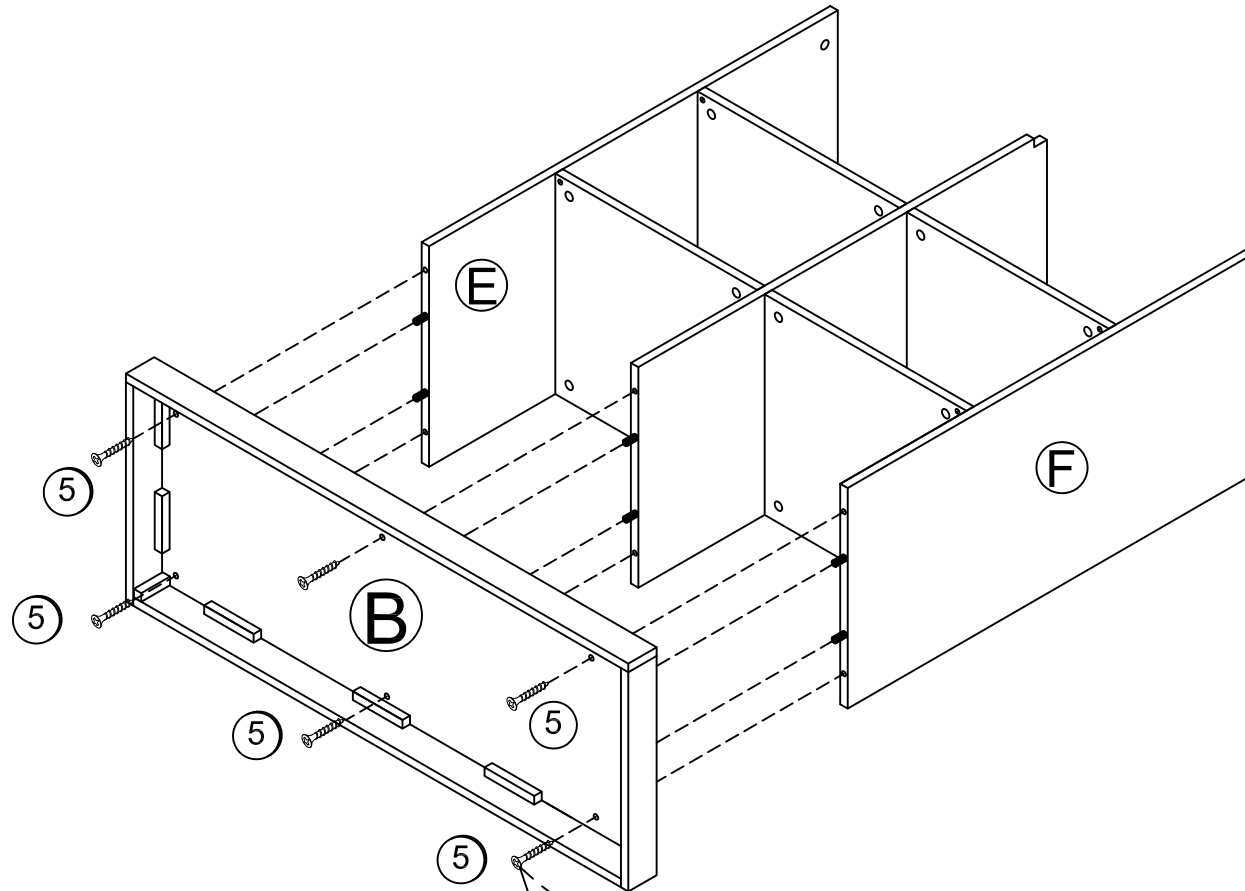

Use one drop of glue in dowel hole.  
Use una gota de pegamento en el agujero de clavija.



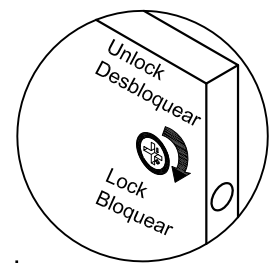
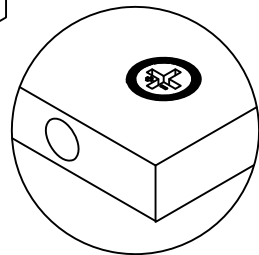
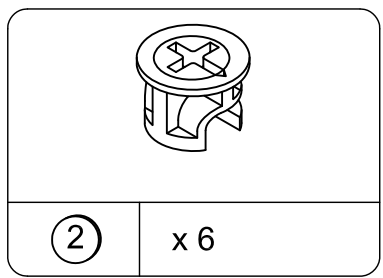
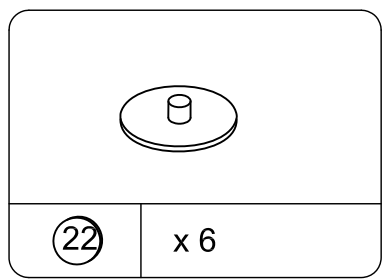
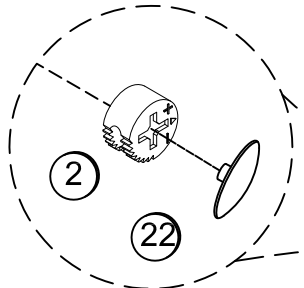
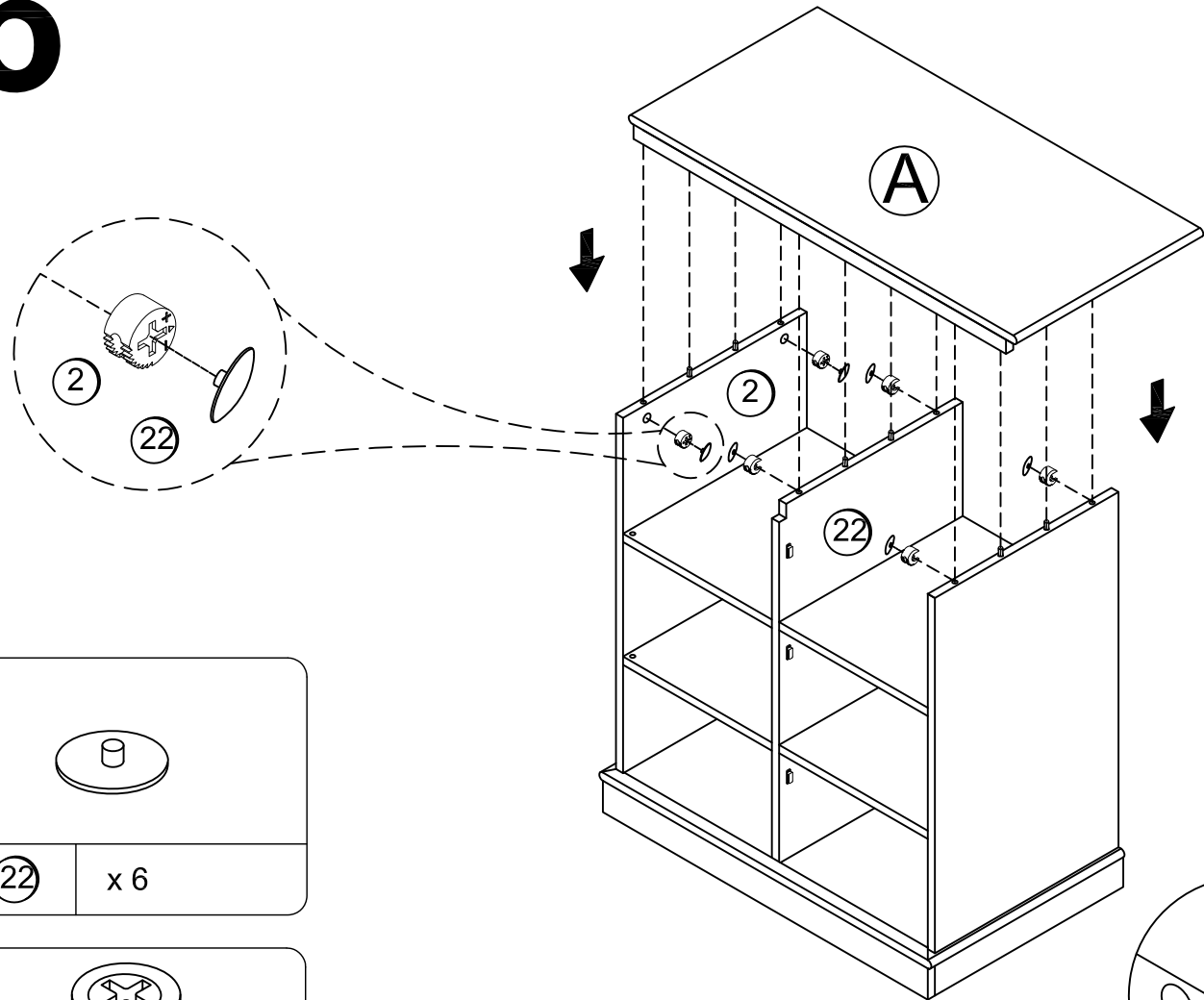







# 6

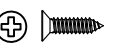

Proper orientation of cam lock  
La orientación apropiada para el seguro de bloqueo

# 7

The knobs (15,16&17) are interchangeable. You can change them if you prefer.  
 Los tiradores (15,16&17) son intercambiables. Puede cambiar los si lo prefiere.

	
16 x 1	21 x 7
	
15 x 1	20 x 1
	
14 x 2	19 x 1
	
10 x 6	18 x 1
	
9 x 6	17 x 1

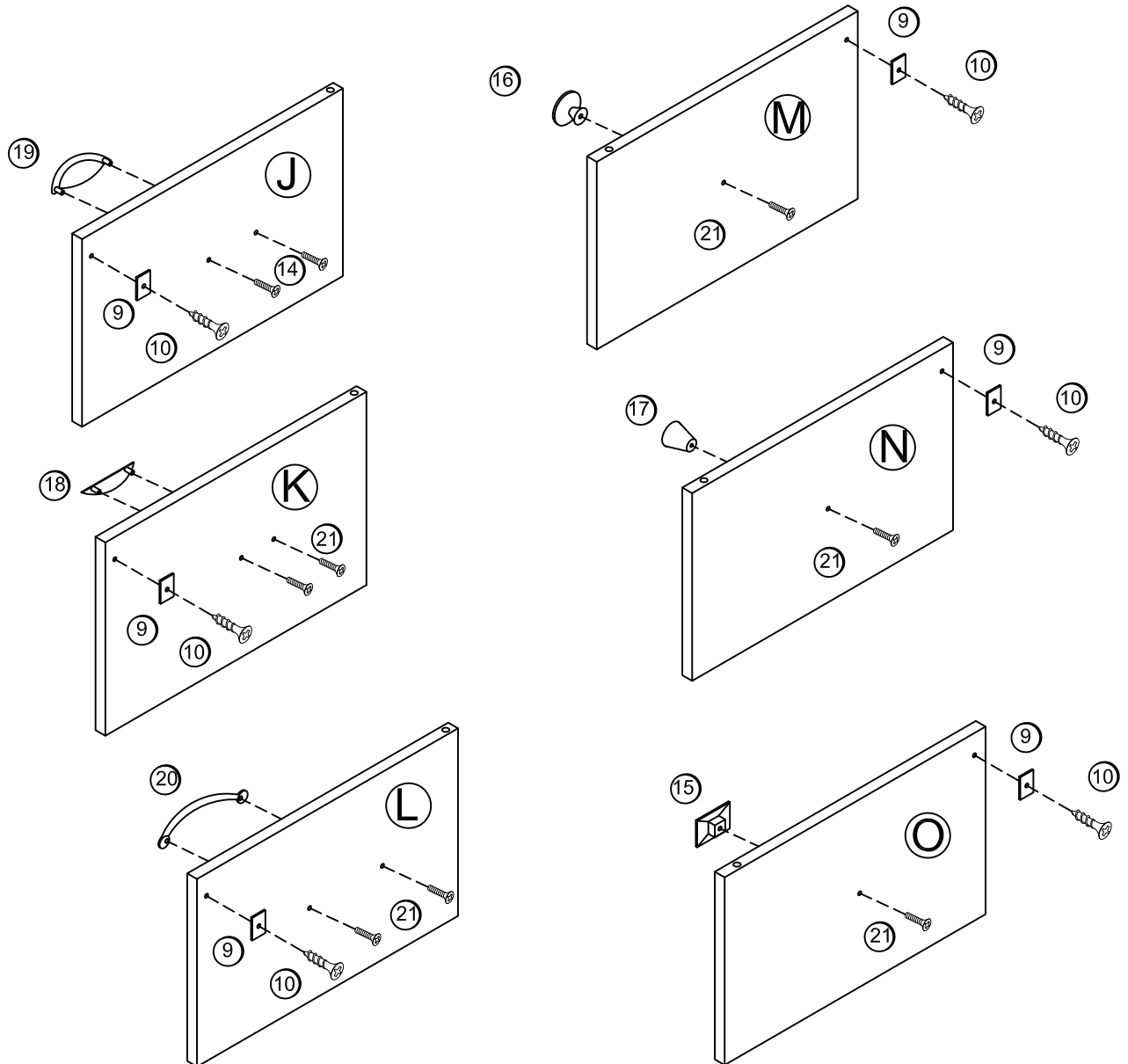

# 8

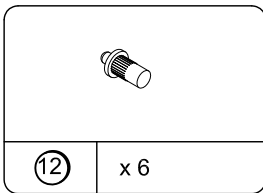
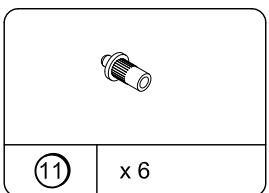
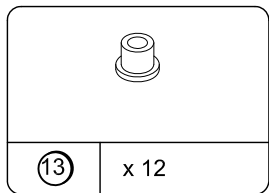
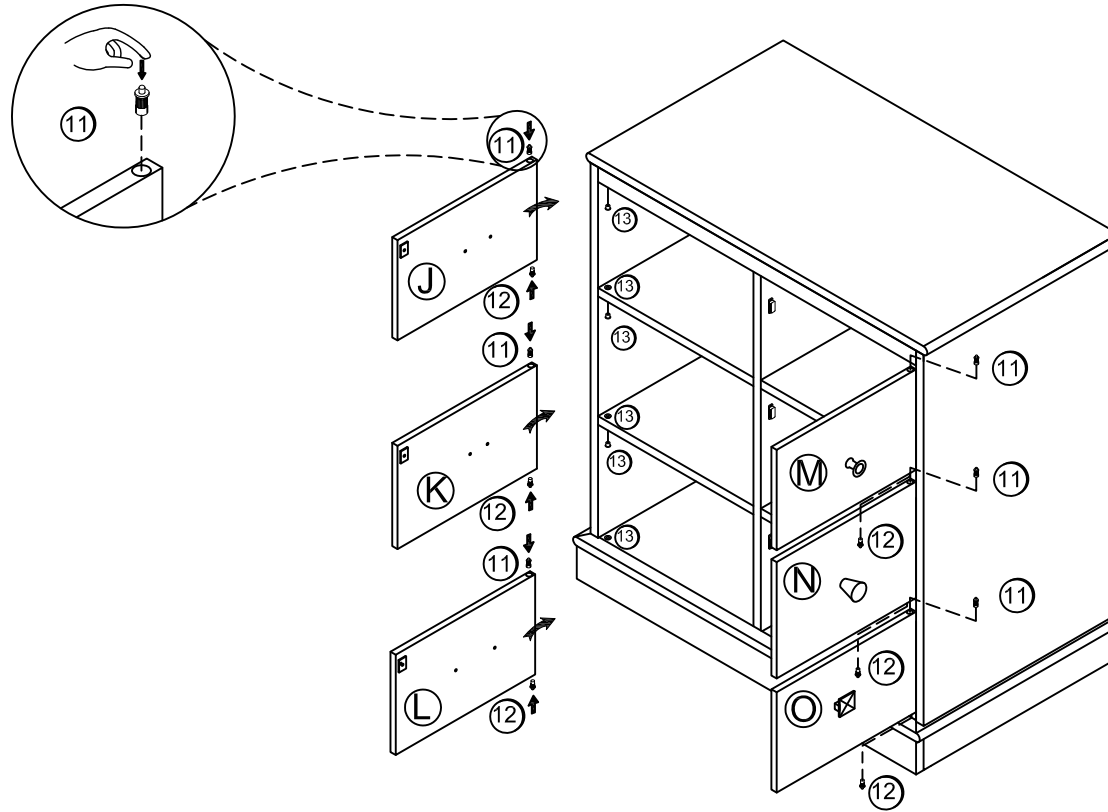

# 9

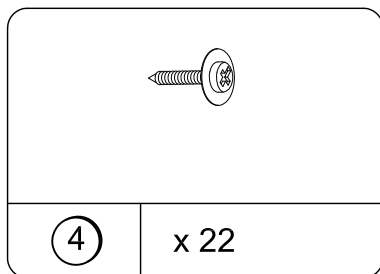
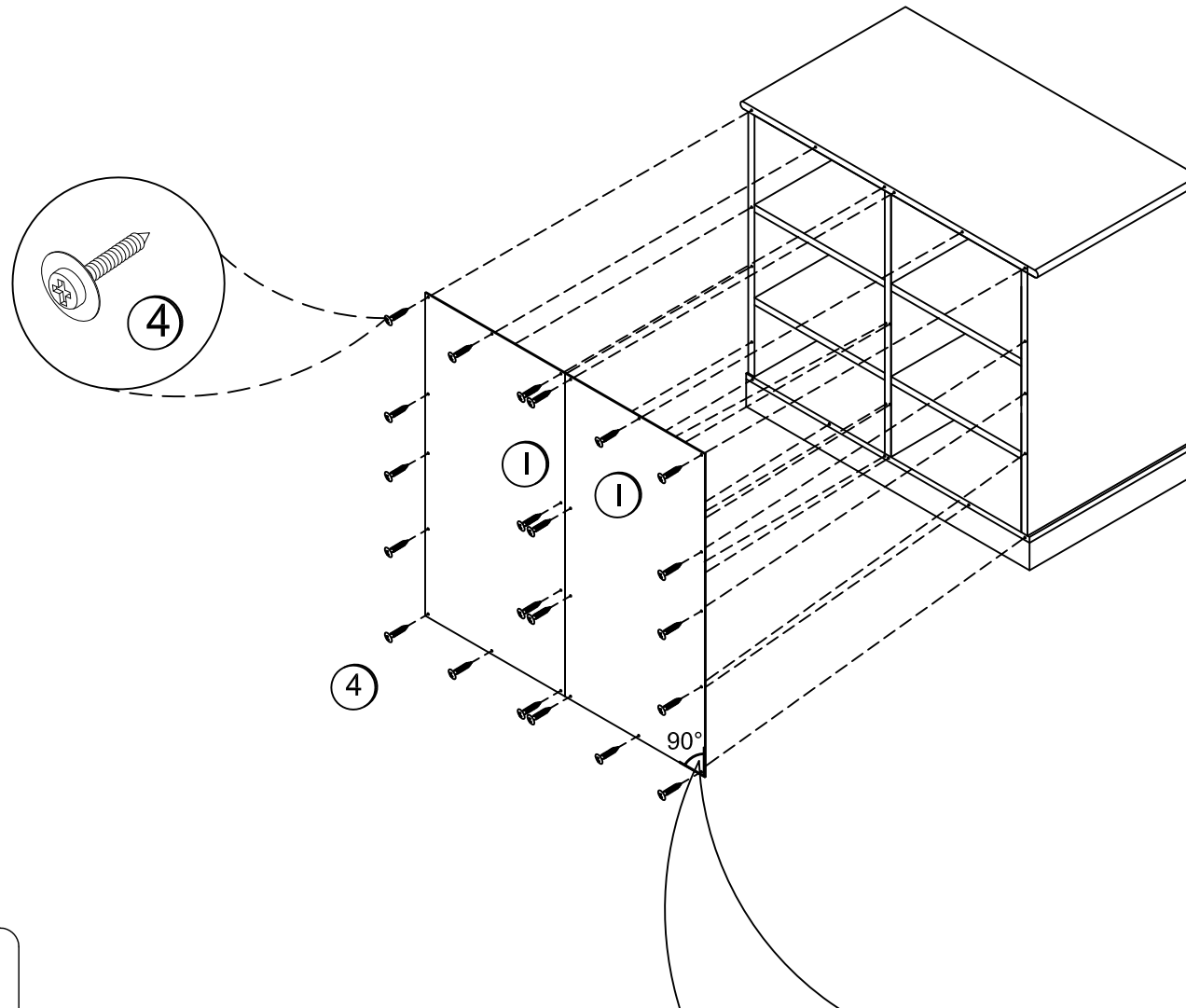

Before attaching the back panel, be sure that the unit is at 90°.  
Antes de atar el panel trasero, asegúrese de que la unidad está a 90°.

WEIGHT LIMITS:  
LÍMITES DE PESO:

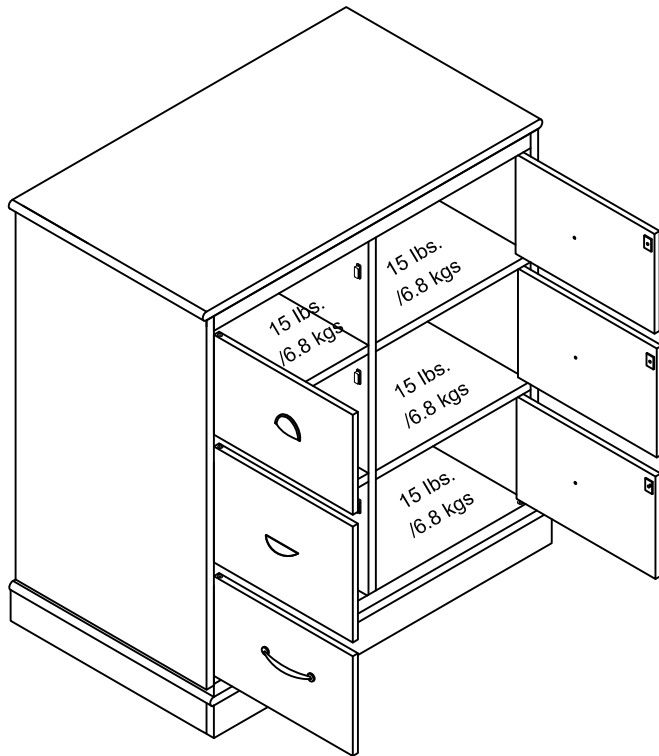

This unit has been designed to support the maximum loads shown. Exceeding these load limits could cause sagging, instability, product collapse, and/or serious injury.

Esta unidad se ha diseñado para apoyar las cargas máximas mostradas. Exceder estos límites de carga podría causar ceder, inestabilidad, derrumbamiento del producto, y lesión seria.

**▲ WARNING**

Please make sure that all objects are removed before moving the assembled unit.

The unit must be team lifted, not dragged or pushed.

Failure to do so could cause instability, product collapse, and/or serious injury.

**▲ ADVERTENCIA**

Por favor mueva el mueble cuidadosamente con la ayuda de otra persona. Levante y mueva el mueble a su lugar. No lo arrastre o empuje, de lo contrario puede haber inestabilidad en el mueble y este puede colapsar u ocasionar graves lesiones.

Enjoy Your Furniture  
DISFRUTE DE SU MUEBLE